

PRODUCT SPECIFICATIONS SHEET

Model: Go-Chair

Document Information: INFINF B3481/Rev C/July 2018

Class of Use ⁷	A
Weight Capacity	300 lbs. (136 kg/21 stone 6 lbs.)
Maximum Speed ¹	Up to 3.75 mph (6 km/h)
Ground Clearance ²	1.75 in. (45 mm) at motor 2 in. (48 mm) at frame
Turning Radius ²	25.5 in. (645 mm)
Overall Size ^{2, 6}	Length: 33 in. (838 mm) with front riggings 26 in. (660 mm) without front riggings Width: 22.5 in. (574 mm)
Drive Wheels	9 in. (229 mm), solid
Caster Wheels	6 in. (152 mm), solid
Rear Anti-tip Wheels	3 in. (76 mm), solid
Suspension	Limited
Range ^{1, 4, 8}	18 Ah: Up to 8.75 miles (14 km) 18 Ah Extended Range: 11 miles (18 km) 22 Ah: Up to 10.75 miles (17 km)
Component Weights ^{5, 2}	Front Section: 31 lbs. (14 kg) Rear Section: 36 lbs. (16.5 kg) Seat: 30 lbs. (13.5 kg) Batteries: 31.75 lbs. (14.5 kg) (battery box)
Drivetrain	Two motor, rear-wheel drive
Brakes	"Intelligent Braking" electronic regenerative, disc park brake
Batteries ³	Two 18 Ah, 12 volt, deep-cycle Two 18 Ah Extended Range, 12 volt, deep-cycle Two 22 Ah, 12 volt, deep-cycle
Battery Charger	18 Ah: 2-amp, off-board 22 Ah: 3.5-amp, off-board
Freewheel Operational Force	Less than 60 N
Drive Control Operational Force	Less than 5 N
Maximum Rated Slope	6° (10.5%)
Maximum Obstacle Climbing Ability (Ascending/Descending)	1.25 in. (30 mm)
Measured Sound Level (A-weighted)	Less than 65 dB

¹ Varies with user weight, terrain type, battery amp-hour rating (Ah), battery charge, battery condition, tire type, and tire condition. This specification can be subject to a variance of +10%, -5%.

² Due to manufacturing tolerances and continual product improvement, this specification can be subject to a variance of (+ or -) 3%.

³ AGM or Gel-Cell type required. See "Batteries and Charging".

⁴ Tested in accordance with ANSI/RESNA, WC Vol 2, Section 4 & ISO 7176-4 standards. Results derived from theoretical calculation based on battery specifications and drive system performance. Test conducted at maximum weight capacity.

⁵ Battery weight may vary based on manufacturer.

⁶ Dimensions listed are for power base only. Overall measurements will vary based on seating and accessory selections.

⁷ Using 22 Ah batteries.

⁸ Unit configured with 18 Ah batteries does not comply with AS/NZS 3695.2 and EN12184 standards.

NOTE: This product conforms to all applicable ANSI/RESNA, ISO 7176 series, AS/NZS 3695.2, and EN12184 standards. All specifications subject to change without notice.



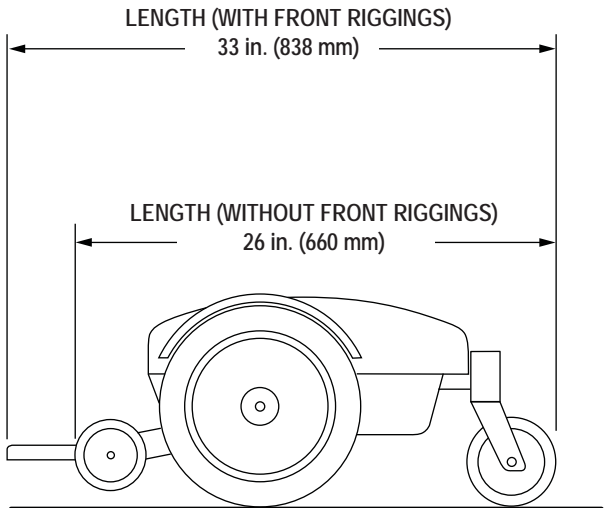

TURNING RADIUS

