

PRIDE[®]
MOBILITY
LIVE YOUR BEST[®]

OWNER'S MANUAL
GoGo Ultra



pride-mobility.co.uk



Owner's Manual – Go Go Ultra (SW1000A3)

Suzhou Sweetrich Vehicle Industry Technology Co., Ltd. provides you with convenient electric mobility scooters. This manual will help you familiarize yourself with the features and functions of the mobility scooter SW1000A3. It includes information on daily use, general maintenance, as well as the high-quality standards and warranty details that we uphold.

Note: In this manual, Suzhou Sweetrich Vehicle Industry Technology Co., Ltd. will be referred to as "we", and all illustrations are for reference only, with the actual product taking precedence.

P4020346/Rev A/02JUNE2025



TABLE OF CONTENTS

1. Introduction	page 3
2. General Warnings.....	page 4
3. Quick Start Guide	page 5
4. Features	page 7
5. Getting On or Off the Scooter	page 8
6. Tiller Console.....	page 9
7. Tiller Console Function.....	page 11
8. Freewheel Mechanism	page 13
9. Seat Removal and Adjustment	page 14
10. Tiller and Battery and Charging.....	page 16
11. Transportation.....	page 20
12. Guidance for Safe Operation and Use.....	page 23
13. Battery and Charging Information	page 28
14. General Warnings.....	page 31
15. EMC (EMI) Warnings	page 35
16. Specifications	page 41
17. Routine Maintenance.....	page 42
18. Service History	page 45
19. Trouble Shooting Guide	page 47
20. Guarantee	page 50

1.INTRODUCTION

We have 14 years of experience in manufacturing mobility scooters and power wheelchairs. All of our products undergo strict testing to ensure they meet our requirements for comfort, safety and durability in mobility scooters. Our success is based on our strong sense of responsibility toward our customers, the value of our products and our tradition of quality. We take pride not only in designing and manufacturing the most innovative products but also in our commitment to providing high-standard services in both sales and after-sales support.

Before using your mobility scooter, please **read this manual carefully**. It will provide you with the necessary information. If you have any questions regarding the use or maintenance of the mobility scooter, please contact your local dealer.

This scooter is classified as a Class C vehicle according to the European wheelchair standard EN 12184.

We are committed to providing products that fully meet the required quality standards and fulfill their intended purpose. We follow the internationally recognized ISO 9001 quality management system to ensure we meet all customer quality requirements. Should you need any further assistance, please contact your local dealer.

Customer Service Provider:

SUZHOU SWEETRICH VEHICLE INDUSTRY TECHNOLOGY CO., LTD

Building B, No.7 Chao Qian Road, Suzhou Industrial Park , Suzhou, Jiangsu Province,



2.GENERAL WARNINGS

- DO NOT OPERATE THE MOBILITY SCOOTER BEFORE READING AND UNDERSTANDING THIS INSTRUCTION MANUAL.
- IF YOU ARE IN DOUBT ABOUT THE MEANING OF THESE INSTRUCTIONS, OR ANY OF THE CAUTIONS AND WARNINGS, PLEASE CONSULT YOUR HEALTHCARE PROFESSIONAL, DEALER OR RELEVANT TECHNICAL PERSONNEL.
- FAILURE TO FULLY UNDERSTAND THE OPERATION OF THE MOBILITY SCOOTER MAY RESULT IN AN UNEXPECTED RESPONSE FROM THE EQUIPMENT WHICH CAN IN TURN LEAD TO POSSIBLE INJURY OR DAMAGE.



NOTES:

Warning and Caution notices used in this manual, apply to hazards and unsafe practices that could result in personal injury or damage to property.



Warning

Falling off a mobility scooter is a very serious incident. We strongly advise against operating the mobility scooter inside a moving vehicle. In such situations, users should place the mobility scooter in the vehicle's trunk and secure it as much as possible during transportation.

Intended Use

Our mobility scooters are designed as mobility aids for individuals with difficulty walking, including people with disabilities, patients and the elderly. Our products are suitable for people of all ages with these special needs. They are designed for outdoor use and can support users weighing up to 120 kg (264 lbs). Overloading may result in changes to performance.

Expected service life

The expected service life of the personal vehicle is one year.

3. QUICK START GUIDE

Assembly

When lifting always keep the back straight, bend at the knees and use the lifting handles provided. Ensure your freewheel mechanism is fully engaged, so your mobility scooter cannot move while assembling. Set the tiller by rotating the tiller folding knob while moving the tiller upwards. Remove the basket from the footboard and place on the bracket located on the front of the tiller. Lift the seat onto the seat post and press down to ensure it is fully engaged.

Battery Charging

The battery MUST be charged for 12 hours before first use. Do not use the mobility scooter unless the battery has been fully charged as failure to do this will result in battery damage. Connect the battery charger to the charger power cord receptacle and a standard electrical outlet.

RED light = Charging

GREEN Light = Charge Complete

Charge the mobility scooter overnight after each use to maintain battery condition.

If you have any questions or require further clarification, please consult the accompanying manual for detailed information.

Typical Use

Designed for use on footpaths, for crossing roads and shopping. It should not be driven through mud, water, snow, sand, loose gravel, long grass or any other unsound surfaces.

Control Functions

Your mobility scooter is equipped with the following features located on the tiller console: on / off switch, battery gauge, speed control, headlight, horn and directional control levers. If you have previously used or owned a mobility scooter you **MUST** still read this Owner's Manual carefully to fully understand the controls and safety warnings. If you are in any doubt of their functions then please turn to page 9 and 11 of this manual.

Transporting

Your mobility scooter may be disassembled quickly and simply for transportation. Please see below:

- Lift off the front basket
- Remove the seat, leaving the seat stem in position
- Place the basket on the floor mat appropriately
- Lower the tiller, using the folding knob, to its lowest setting locking in the basket. Make sure that there is at least 30mm between Tiller and battery pack.
- Using the lifting handles provided carefully lift the scooter safely and securely into the vehicle
- To reassemble the mobility scooter reverse the sequence above



TIP:

Using the front bumper and rear lifting handle provided carefully lift the mobility scooter.



Important:

- When reassembling the mobility scooter, remember to insert the battery locking pin. Failure to do so may result in the batteries disengaging during use.
- Always secure your mobility scooter parts before transportation.
- Remember to engage the drive unit by pushing the freewheel lever forwards to stop the mobility scooter from moving.

If you have previously used or owned a mobility scooter, you must still carefully read this manual to fully understand the controls and safety warnings. If you have any questions about the functionality, please refer to this manual.

4.FEATURES

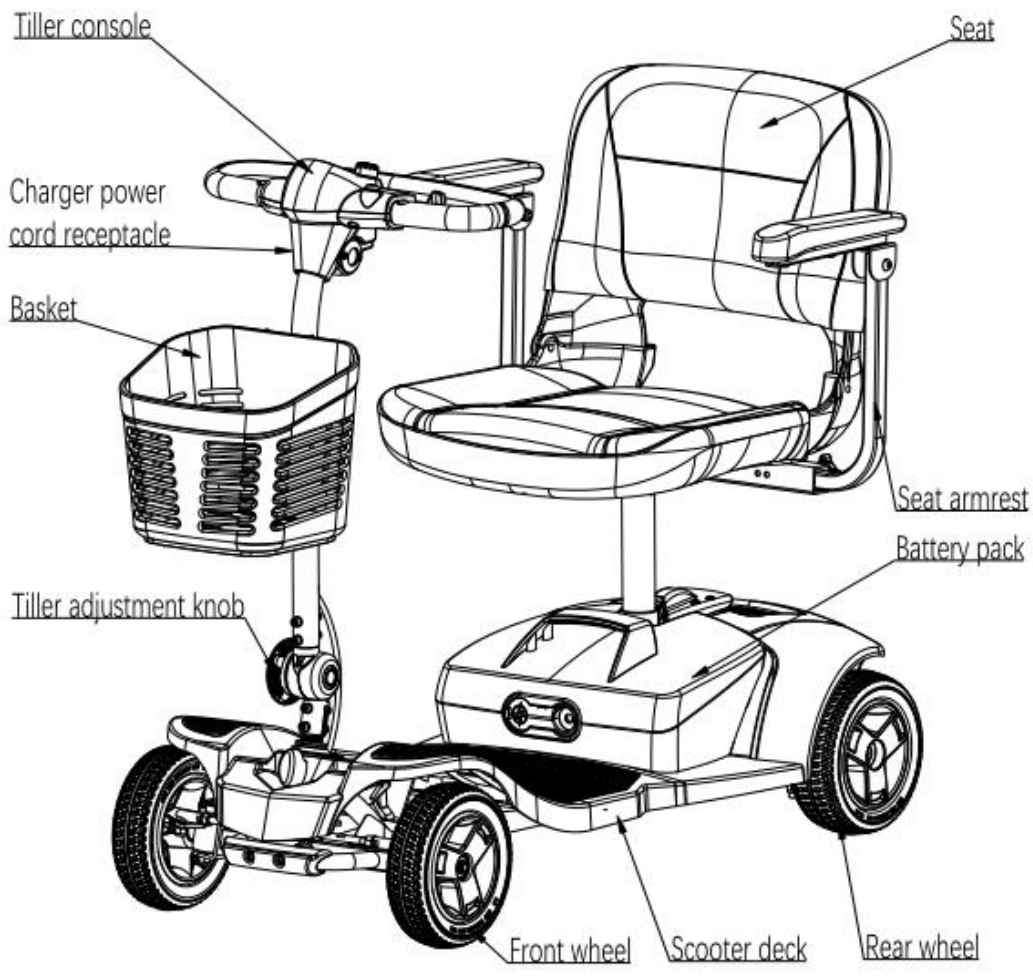

5.GETTING ON OR OFF THE SCOOTER

Getting on the mobility scooter:

- 1.Ensure the key switch is turned to the OFF position (Figure 5.1).
- 2.Adjust the seat to an upright position and flip the side armrest back, as shown in (Figure 5.1).
- 3.Once all your adjustments have been made, then turn the key switch to the ON position.

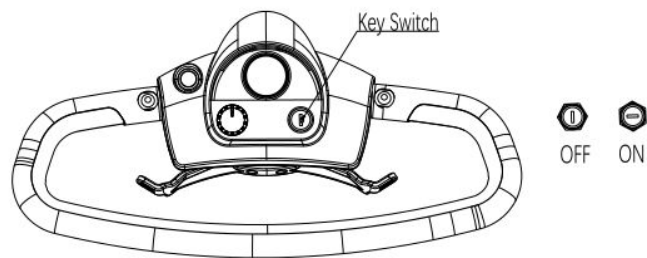

Figure 5.1

Getting off the mobility scooter:

- 1.Bring the mobility scooter to a complete stop and turn the key switch to the OFF position.
- 2.Place both feet on the ground, flip the side armrest back, and gently leave the seat.

6.TILLER CONSOLE

Hand Controls

All of the drive controls for the mobility scooter are to be found on the tiller console (Figure 6.1).

The Preset Speed Knob

- Turning this knob to the left, reduces your available maximum speed.
- Turning it to the right, increases the available maximum speed.

The Battery Gauge

This gives an approximation of battery charge and is illuminated for clarity.

The gauge is “RED” empty, to “YELLOW” charge required, to “GREEN” charged.

As the scooter moves over differing terrain, the battery gauge will go up and down. This is normal. For a more accurate indication, stop the scooter and note the reading. In cold, damp weather the gauge will dip more often as the capacity and efficiency of all batteries drops in such conditions.



TIP:

If your battery gauge has gone into the “RED” section you can increase your remaining range by reducing your maximum speed. Remember you **MUST** charge your battery overnight as soon as you can to prevent battery damage.

Operating the Lights

The lights are operated by pressing the blue button on the front tiller panel. Press the button once to illuminate the lights, press the button again to switch the lights off. Switch the lights on to make yourself more visible in low levels of light, day or night.

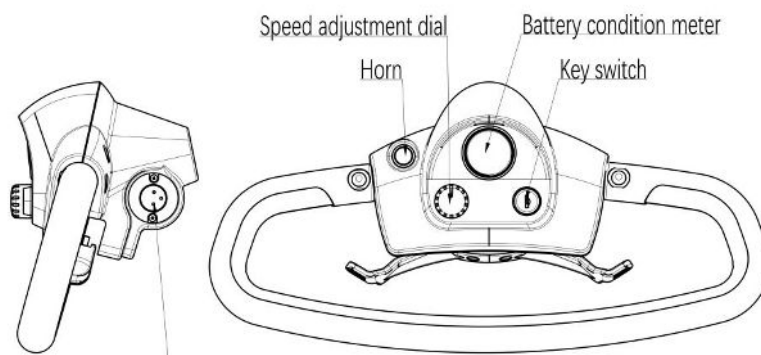

Figure 6.1

7. TILLER CONSOLE FUNCTION

Throttle Lever

The speed control lever manages the mobility scooter's speed as well as forward and reverse movement:

- To move forward, press the right side of the throttle lever downward. The greater the angle, the faster the scooter will go (Figure 7.1).
- To move backward, press the left side of the throttle lever downward. The greater the angle, the faster the scooter will reverse (Figure 7.2).
- Releasing the throttle lever will slow the mobility scooter down to a stop.

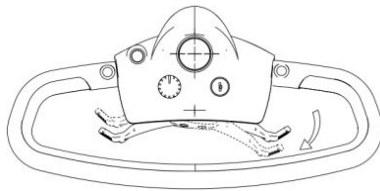

Figure 7.1

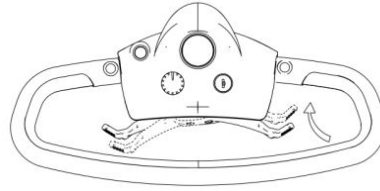

Figure 7.2

Horn Button

Press the horn button to produce a warning sound, alerting pedestrians around you.

Key Switch

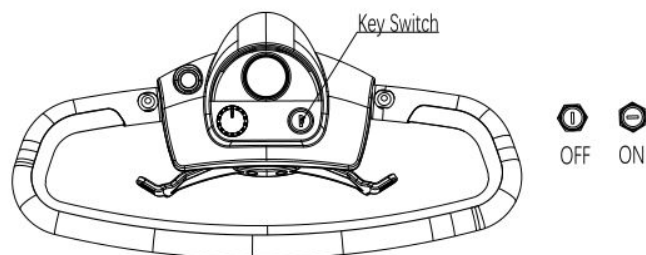

Figure 7.3

The key switch turns the mobility scooter ON and OFF. Please note that the key cannot be removed when it is in the ON position (Figure 7.3).

Before Getting on or off the mobility scooter ensure that the key switch is in the OFF position (Figure 6.1). Turning the key while driving may cause the mobility scooter to stop suddenly. This is not recommended unless in an emergency, as frequent use of this feature can lead to mobility scooter malfunctions.

Charging Port

The charging port is located on the battery box beneath the seat.

- Open the protective cover of the charging port to fully expose the socket.
- After charging, return the protective cover to its original position to prevent water from entering the charging port.



Warning

Do not attempt to charge the mobility scooter outdoors or in damp environments. Failure to follow the instructions may result in the risk of electric shock or fire!

8.FREEWHEEL MECHANISM

A freewheel device disengages the power drive to allow manual operation (i.e. the mobility scooter can be pushed at a walking pace). See figure 8.1. This safety function can prevent your mobility scooter from being driven by someone illegally when parking. By pushing BACKWARD the lever that is located on the right hand side of the mobility scooter rear panel can engage the motor for you to drive.

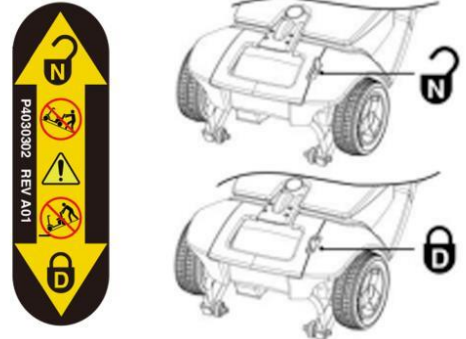

Figure 8.1

Warning

Especially when going uphill, ensure the brake lever is engaged. If the mobility scooter is released without engaging the brake, it may roll backward.

After use, always ensure the brake lever is in the engaged position to prevent unauthorized operation, which could result in damage or injury.

9. SEAT REMOVAL AND ADJUSTMENT

Seat Rotation Adjustment

The seat rotation lever, located on the right side of the seat base, secures the seat into several positions. Figure 9.1

1. Pull up on the seat rotation lever to disengage the seat.
2. Rotate the seat to the desired position.
3. Release the lever to secure the seat into place.

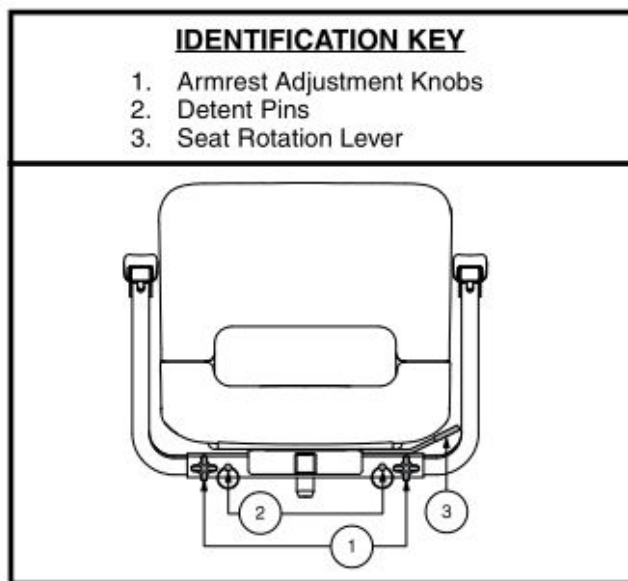

Figure 9.1

Armrest Width Adjustment

The armrest width can be adjusted inward or outward.

1. Loosen the armrest adjustment knobs. See Figure 9.1
2. Use the attached ring to pull and remove the detent pins.
3. Slide the armrests in or out to the desired width.
4. Align the adjustment holes on the seat frame and armrest, then reinsert the detent pins.
5. Tighten the armrest adjustment knobs.

Seat Height Adjustment

The seat can be repositioned to different heights. See Figure 9.2

1. Remove the seat and battery pack from your Travel Scooter.
2. Use the attached ring to pull and remove the detent pin from the lower seat post.
3. Raise or lower the upper seat post to the desired seat height.
4. While holding the upper seat post at that height, align the adjustment holes of the upper and lower seat posts.
5. Fully insert the detent pin.
6. Replace the battery pack and seat.

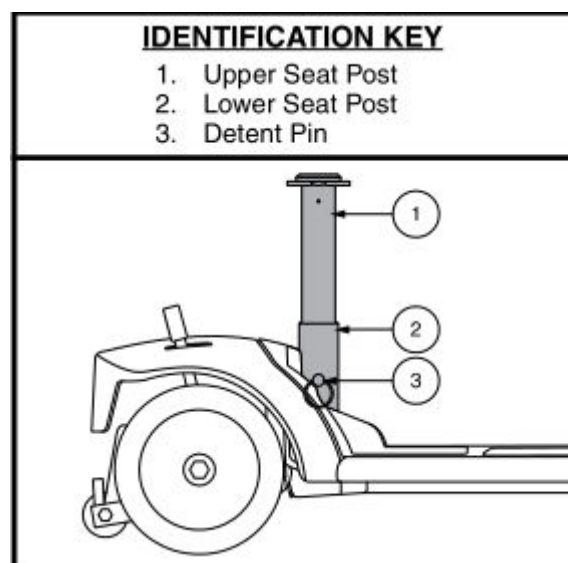

Figure 9.2

10.TILLER/BATTERY/CHARGER

Tiller Adjustment

The mobility scooter features an infinitely adjustable tiller which allows you to lock the tiller in the most comfortable driving position. This feature also lets you fold the tiller down fully, for transportation and stowage.

The folding knob is located on the bottom of the tiller.

1. Hold the tiller with your left hand.
2. Rotate the folding knob anticlockwise to release the tiller (Figure 10.1).
3. Move the tiller to the desired location.
4. Rotate the folding knob clockwise to lock the tiller (Figure 10.1).

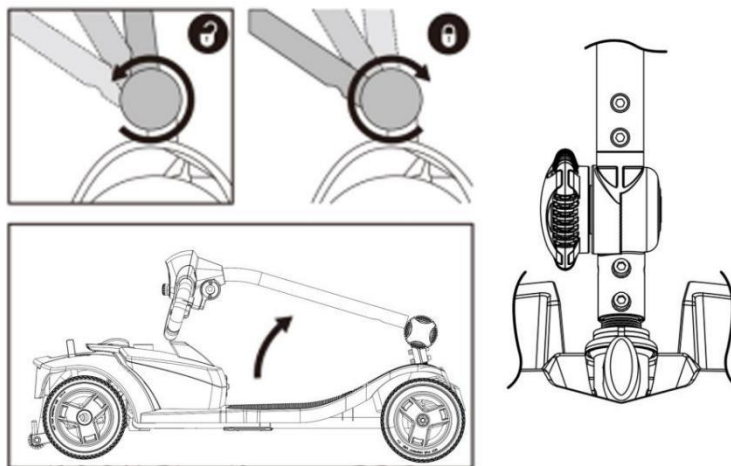

Figure 10.1

Battery Replacement

Grip the battery handle with your hand and pull it up vertically with force to remove the battery. Please keep your back straight and bend your knees.

Battery Charging Instructions

Your mobility scooter comes with an off-board charging facility (Figure 10.2). Please note that only chargers with a minimum capacity of 2.0A and a maximum of 5.0A, provided by authorized local dealers, should be used.

There are two charging ports. The first one is located on the lower left side of the dashboard, and the second one is at the front of the battery box (Figure 10.3).

1. Turn off the scooter. Switch off the mobility scooter at the key switch.
2. Connect the charger. Rotate the cover on the charger connector located on the battery pack and connect the charger, as shown in (Figure 10.3).
3. Plug in the charger. Before connecting the charger plug to the power outlet and turning on the power, ensure the charger plug is dry and undamaged.

Note: Before charging, please make sure that the overload protector is not popped out.

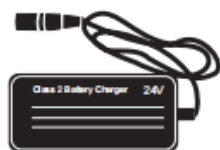

Figure 10.2

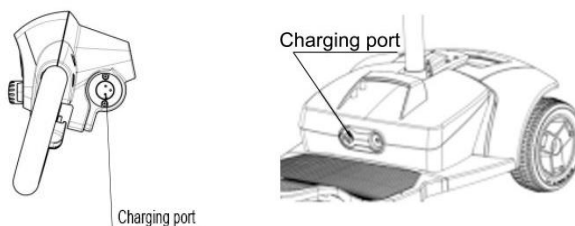

Figure 10.3



Note:

The charger is capable of charging from 100V to 240V, and 2Amp. The off-board charger has 2 possible indications:

1. RED = Power is on.
2. GREEN = fully charged.

Ensure the mobility scooter is switched off before commencing the charging process. After charging, always move the charging socket cover back into place.

Occasional use of the wheelchair before charging is acceptable if urgently needed.

Please note that the scooter has a safety circuit to prevent it from being driven off during charging. If your scooter fails to respond to normal control after a charging period, please check that the battery charger has been completely disconnected from the scooter.

The off-board charger must be kept dry in temperatures between -25°C and 40°C and not be subjected to mechanical damage. In all cases, the charger must only be repaired by an authorized dealer.

 **Important!**

- Only use the original charger from our company. Using chargers from other brands may void your warranty. Using an unknown charger could damage your scooter, and using an incorrect charger could pose a fire hazard.
- Handle and dispose of the battery and charger carefully.
- Do not throw the battery into fire. You should dispose of used batteries according to local regulations.
- Do not place the battery near any heating devices, as this could cause the battery to explode.
- Do not press or puncture the battery, or subject it to high pressure, as this could cause a short circuit or overheating.

 **Warning!**

- Do not charge the battery in a smoking or open flame environment. Charging may generate explosive gases, so the scooter and battery charger should be kept away from sources of fire, such as flames and sparks.
- Charging should take place in an area at least twice the volume of the scooter, with adequate ventilation to prevent the accumulation of combustible gases.
- Off-board chargers should not be carried on the scooter.
- Do not touch the metal terminals of the battery.
- Only replace the battery with the specific type designed for your scooter.
- If the battery or battery pack is visibly damaged, contact your local dealer immediately. Do not attempt to repair the battery yourself.
- It is warned not to operate the scooter with the battery dead, as the rider may become trapped.

 **Dealer Warning!**

- When handling leaking batteries, wear gloves and safety goggles.
- Replace damaged or leaking batteries promptly.
- Charging areas may accumulate gases.

Fuses

There is a reset button on the top of the battery box. Once there is an overload of current, the internal button will pop out, closing the key switch. Press the reset button, then open the key switch and restart the mobility scooter. The fuse on the battery is 30A. If you need to replace the fuse, please contact the local dealer.

11. TRANSPORTATION

Packaging

Pack the mobility scooter as follows to prevent it from moving or getting scratched.

1. Fix the mobility scooter in the cardboard box by using custom foam blocks. Remove the seat and place it on the upper part of the pedal. Rotate the steering lever downward and lock it in place to the upper part of the seat. (Figure 11.1)

2. Fix the seat armrests and the bottom tube of the seat cushion respectively to the upper position of the folding device by means of custom foam and fix the battery and the basket to the upper position of the rear cover of the vehicle. Use two pieces of foam to elevate the battery as shown in (Figure 11.2).

3. Put on the battery and the car basket weights, close the carton and secure it with professional ropes to form a complete package (Figure 11.3).

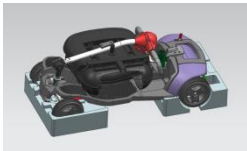

Figure 11.1

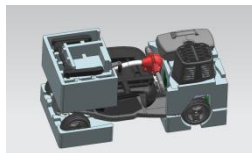

Figure 11.2

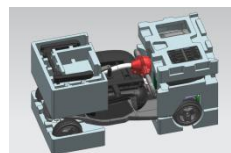

Figure 11.3



Important Notice

The packaging boxes we use comply with the GB/T4857.18 (ISO4180/2) testing standards:

1. The box meets the vertical impact test from a height of 500mm.
2. The box meets the stacking test for highway transportation with a height of 2.5m.

Guidelines

1. Before unpacking, ensure the outer appearance of the box is intact, with no visible damage, dents, or issues with the product's serial number and other basic information.
2. Unpack in reverse order: remove the mobility scooter and associated items such as the user manual, warranty card, inspection report and certificate of conformity.
3. Read the provided materials thoroughly to familiarize yourself with the assembly and operation processes of your product.
4. Turn on the power and check if the mobility scooter is functioning properly.

Transportation Instructions

Your mobility scooter can be quickly and easily disassembled for transportation.

1. Remove the basket.
2. Remove the seat and the armrests.
3. Fold the seat and place it inside the vehicle body.
4. Place the battery box and the front basket in the foam trough.
5. Fasten the foam on the upper part and pack the packaging box properly.



Tips:

1. While the mobility scooter can be simply secured in a transport box, to avoid potential issues during transit, we recommend using the provided packaging. After packing the mobility scooter, secure it properly within the box for transportation.
2. When reassembling the mobility scooter, follow the above steps in reverse order.



Cautions:

1. When reassembling the scooter, ensure the battery locking pin is inserted, or the battery may fail to supply power during use.
2. Before transportation, confirm that all mobility scooter components are secure.
3. Ensure the rear brake lever is engaged to prevent the mobility scooter from moving during transportation.
4. Do not ride the mobility scooter during transportation.

Packaging and transportation environment conditions

The mobility scooters can be transported by common transportation vehicles, but you need to prevent them from strong impact, vibration or snow and rain. This is clarified in the order contract.

The packaged mobility scooter should be put into an environment between -20°C~ 45°C temperature with humidity less than 93% with no congeal or corrosive air with good ventilation.

12. GUIDANCE FOR SAFE OPERATION AND USE

Basic Driving



Caution!

It is advisable during the first few sessions of operating your mobility scooter that the area around you is clear of obstacles and pedestrians.

Before operating your mobility scooter, ensure the seat height and position has been adjusted to your satisfaction and the tiller angle has been set for optimum safety and comfort.

Please see the “General Warnings”, “Getting on Your Mobility Scooter” and “Tiller Adjustment” sections in this manual.

1. Make sure you are properly seated on the mobility scooter and that the speed control knob is turned fully to the left.
2. Turn the key switch to the “ON” position.
3. On the tiller, use the throttle lever as described earlier. You will gently accelerate. Release and you will gently stop. Practice these two basic functions until you get used to them.
4. Steering the mobility scooter is easy and logical. Be sure to remember to allow enough clearance when turning corners so that the rear wheels clear any obstacle.
5. Short cutting a pavement corner can cause the back wheel to go off the pavement, causing problems if the corner is very rough. Avoid this at all times by steering a wide curve around the obstacle.
6. When steering in a tight spot, such as entering a doorway or when turning around, stop the mobility scooter and then turn the handlebar to where you want to go, then apply power gently. This will make the mobility scooter turn very sharply. It is also recommended that the preset speed is set to a slower setting to aid control in tight spots.
7. Reversing requires attention - exercise caution when reversing especially down slopes. When reversing, always turn the handlebars in the opposite direction to the way you want to go. The more you operate the throttle lever, the faster you will go. Reverse speed is 50% slower than forward speed. If the mobility scooter does not move in reverse, carefully turn the speed control knob clockwise until the mobility scooter moves gently backwards.



Important:

To preserve battery power there is a “sleep timer” feature built into the controller. Should the mobility scooter be left ON, but not operated for 15 minutes the mobility scooter will go into “sleep mode”. To reset this, switch the mobility scooter OFF and then back ON again.



Note: The user’s visual standards must be higher than 0.5.

Climbing Capabilities

This mobility scooter has passed the test requirements for climbing a slope of up to 8° with a load of 120kg (264lbs) (Figure 12.1). Please do not attempt to climb slopes steeper than 8° (the maximum uphill and downhill gradient is 8°).

- When reversing on a slope, slow down.
- When reversing downhill, do not exceed a 6° slope and exercise extra caution.
- Do not attempt to drive the scooter on mixed surfaces (e.g., simultaneously on the sidewalk and roadway).



Figure 12.1

Factors Affecting Climbing Ability, Driving Range, and Battery Usage Time:

- User’s weight
- Terrain (e.g., grass or gravel)
- Slope gradient
- Battery charge level and lifespan
- Extreme temperatures
- Use and weight of accessories

Traveling across slopes

Care should be taken traversing across a slope, always reduce your speed. Do not traverse across the face of a slope in excess of 8° (Figure 12.2) .

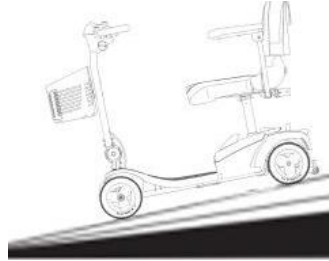

Figure 12.2



Important Notice:

When going up or down a slope, always face the direction of the slope. Do not drive on slopes steeper than 10°. Failure to follow this requirement may result in tipping over.



Warning:

The stopping distance on a slope can be significantly greater than on a flat surface. Proceed with caution.

Braking:

- Simply release the accelerator lever, and the mobility scooter will come to a stop within a few seconds.
- While braking, always keep both hands on the handlebars for stability and safety.



Important Notice:

- Electromagnetic brakes are not instantaneous; they will engage after the wheels have rotated approximately half a turn.

Emergency Braking:

- In an emergency, turning off the key switch will stop the mobility scooter. While effective, this method should never be used under normal circumstances.

Switching off

The mobility scooter must always be switched off at the key switch.

When the mobility scooter is stowed or not in use for a long periods of time, always charge the batteries for 12 hours and then disconnect the battery pack before storing. If the mobility scooter is to be stored for a long period of time remove the fully charged battery packs and store, at or near room temperature, out of freezing conditions i.e. greater than 0°C.

Use on the footpath

When using your mobility scooter on the footpath always be aware of pedestrians and situations which might require extra care. For example, young children and pets. Remember, especially when driving in public places, to drive with caution and have regard for others at all times. When maneuvering in confined areas, including shops, ensure the minimum speed is selected (Figure 12.3). If you leave your mobility scooter outside a shop ensure that it does not obstruct the footpath or vehicular access.

Always switch off and take your key with you.

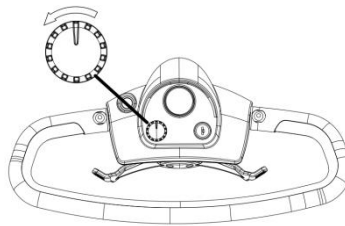

Figure 12.3

Crossing the Road

- The mobility scooter cannot climb over obstacles higher than 57.5mm.
- Before crossing the road, ensure the mobility scooter is positioned perpendicular to the curb at a 90° angle and stopped 30–60 cm away from the sidewalk edge. Proceed only when it is safe.
- Set the speed to medium or high while crossing and do not stop midway.
- The low-speed setting is recommended for going downhill, reversing or turning. Always slow down when turning.
- Safety features should not be removed. Violating these guidelines may lead to tipping over.

Turning

- Always slow down when turning, especially on a downhill slope, as failing to do so could cause the mobility scooter to overturn.
- The mobility scooter has a turning radius of 1.3 meters and can perform a U-turn in a corridor as narrow as 1.5 meters wide.

Using Mobile Devices

- Do not use mobile phones or other wireless devices while operating the mobility scooter.
- Using such devices can generate excessive electromagnetic fields, potentially interfering with the mobility scooter's electronic systems.
- If you must use a mobile phone or wireless device, stop the mobility scooter in advance and turn off the power.

Tires

- Regularly inspect the tires for damage or wear.

Emergency Braking

- In case of an emergency or unexpected movement, you can stop the mobility scooter by turning off the key switch. While effective, this method is abrupt and should never be used under normal conditions.
- Important: Frequent use of emergency braking may damage the motor, potentially rendering the mobility scooter inoperable.

Brake Lever

- Operating the mobility scooter on a slope and releasing the brake lever can be extremely dangerous. If it is necessary, proceed with extreme caution. After use, ensure the brake lever is returned to its engaged position.
- Do not use the mobility scooter if the brakes are not functioning properly.

13. BATTERY AND CHARGING INFORMATION

General information

Batteries are the power source for almost all of the modern mobility products available today. The design of batteries used in mobility products is significantly different from the batteries used to start a car for example. Car batteries are designed to release a large amount of power over a short period of time, while batteries for mobility products (commonly called deep cycle batteries) release their power evenly over a long period of time. Therefore, due to the lower production volumes and increased technological requirements, mobility batteries are typically more expensive. Commonly two 12 volt batteries are used together in a mobility product giving a total voltage of 24 volts. The size of the battery (e.g. its available power) is expressed in amps per hour (e.g. 10amp/hr). The higher the number, the bigger the battery size, weight and, potentially, the greater the distance you can travel.

Batteries

Your mobility scooter is fitted with batteries that require no maintenance, other than regular charging.

If a battery is physically damaged, please use extreme caution when handling it.



Beware! Battery fluids are corrosive and care should be taken at all times to avoid contact with it. If it comes into contact with the skin or clothing, wash immediately with soap and water. If it comes into contact with the eye, immediately flood the eye with running cold water for at least 10 minutes and seek medical attention.

In such an event, call your local dealer for assistance.

Please do not dispose of batteries in normal waste. Always recycle in accordance with local laws.

Maintenance free

The type of battery used in the battery pack has GEL electrolyte which is totally sealed within the battery's outer case. As the name implies, no maintenance is required other than regular charging. As the battery case is sealed, you can safely transport this type of battery without fear of acid spilling. Furthermore, they are approved for transportation on aircraft, boats and

trains. It is recommended that the batteries are always transported and stored upright. Only use batteries supplied by an authorized dealer.

Battery care

We have set out a battery care plan for maintenance free batteries. If a different care plan is followed, this may result in lower than expected performance from your mobility vehicle.



Note: Do not expose any part of the battery to direct heat and when charging always place on a hard surface in a room with good ventilation. You should not charge the batteries in outdoor conditions. Do not smoke when in the vicinity of charging batteries. Extinguish all flames from the area.

Do not allow the batteries to freeze.

Battery Pack Maintenance

1. Only use approved chargers to charge the mobility scooter.
2. The first time you use the mobility scooter, charge the battery for 8-10 hours.
3. Do not interrupt the charging cycle.
4. If the mobility scooter is not in use, the batteries should still be charged regularly (this will not damage the battery). When turning off the power, do not leave the charger plugged into the battery terminals, as this will drain the battery.
5. If the mobility scooter has not been used for more than 30 days, the first charge should be 12 hours. After charging, unplug the charger and ensure the battery is disconnected.
6. Incorrect full-load charging can damage the battery.



Caution: Remember to unplug the charger from the mobility scooter once charging is complete to prevent the mobility scooter from moving. Do not operate the mobility scooter while charging.

7. The battery should be regularly checked for signs of damage. If there is any visible damage, immediately contact your local dealer.



Caution: Be careful not to short-circuit the battery terminals! Before inspecting the battery, remove any conductive jewelry (e.g., watches, necklaces, etc.).

8. Following these eight points will help improve your battery usage, extending the mobility scooter's driving range and prolonging the battery's lifespan.

The range of your mobility scooter

Most manufacturers of mobility products state the range of their vehicles either in the sales literature or within the Owner's Manual.

The range stated sometimes differs from manufacturer to manufacturer even though the battery size is the same. We measure the range of our vehicles in a consistent and uniform manner, but variances still occur due to motor efficiencies and overall product load weight.

The range figures are calculated to I.S.O. Standard 7176, Part 4: Scooter Energy Consumption Theoretical Range.

The range figures stated should be seen as a theoretical maximum and could be reduced if any single, or combination, of the following circumstances occur:

1. User weight heavier than 120kg
 2. Batteries whose age and condition are less than optimal
 3. The terrain is difficult or unsuitable e.g. very hilly, sloping, muddy ground, gravel, grass, snow and ice
 4. The vehicle climbs ramps regularly
 5. The ambient temperature is very hot or very cold
 6. Damage occurring to one or more tyres
 7. Lots of start/stop driving
- Always check that the battery is fully charged before setting off.
 - Ensure the battery is in good condition and there are no signs of leakage.
 - Do not expose the charger, battery, or mobility scooter directly to heat sources (such as flames or open fires).



Important: When riding outdoors, if the voltage meter drops to 23.0V, you can reduce your speed to increase the driving range.

14. GENERAL WARNINGS

User Guidelines

The mobility scooter's driving settings must be adjusted by a professional dealer or technician according to the user's specific needs. This is the responsibility of the dealer and technician. Incorrect settings may cause injury to the user, caregiver, mobility scooter and bystanders. Before operating the mobility scooter, carefully review the manual's instructions and operating procedures. It is best to practice under the supervision of a professional.

Safety Precautions

- Do not operate the mobility scooter if it behaves abnormally or is unstable.
- Do not bend forward to retrieve objects while seated on the mobility scooter, as this may cause tipping and injury.
- Do not use escalators to move the mobility scooter, as it increases the risk of injury.
- Avoid slippery surfaces such as water, oil, ice, or other hazardous materials when going uphill or downhill, as this may cause loss of control.
- Do not attempt to climb obstacles or cross trenches exceeding 45mm, as it may lead to personal injury.
- Do not make sharp turns or reverse suddenly at high speeds.
- Do not lift the mobility scooter by the seat, tiller, panel, or detachable parts. Remove detachable parts first, then lift them separately.
- Do not carry passengers.
- Do not tow another mobility scooter.
- Always inspect the surroundings before operating the mobility scooter.
- Check all fasteners and connectors for proper attachment and secure all detachable parts before use.
- Do not operate the mobility scooter without anti-tip wheels.
- Do not perform unauthorized repairs on any mobility scooter components, accessories, or adapters. Turn off the mobility scooter before getting on or off. When leaving the mobility scooter, always remove the key to prevent untrained individuals or children from attempting to operate it, which could cause damage or injury.

- Do not connect medical devices (e.g., life-support equipment or ventilators) to the mobility scooter's electronic system.
- Do not operate the mobility scooter under the influence of alcohol, drugs, or medications that impair judgment.
- Do not use the mobility scooter if you feel unwell.
- Do not operate the mobility scooter if your vision is severely impaired.
- Any serious incidents related to the equipment shall be reported to the competent authorities of the manufacturer and the user and/or the Member State in which the patient is located.



If you have any concerns about your ability to operate the mobility scooter or questions about medical conditions or related health issues, please consult a healthcare professional.



We hereby declare that we bear no responsibility for accidents or injuries resulting from violations of local or international laws.



Do not attempt to operate the mobility scooter while standing beside it.



Ensure you are seated properly in the seat before operating any functions of the mobility scooter.



Note: Turn on the front headlight when visibility is poor during the day or at night to ensure a clear line of sight.

- Do not stand on any part of the mobility scooter other than the footrest.
- Do not stand on the seat of the mobility scooter.
- Do not sit on the seat without ensuring that it is securely locked; unsafe operation may lead to personal injury.
- Do not operate the mobility scooter when the seat is not securely locked.
- Always face forward while operating the mobility scooter.
- Do not operate the mobility scooter without confirming that the tiller is locked in place; an unlocked tiller may result in injury.
- Do not attempt to ascend or descend slopes exceeding 8 degrees.
- Do not reverse on slopes exceeding 6 degrees.

- When driving on a slope, releasing the speed control lever may cause the mobility scooter to roll backward. The mobility scooter may roll back approximately 30 cm before the braking function activates during forward or reverse operation.
- Before using the mobility scooter, check that all electrical connections are secure.
- Do not disconnect, cut, or modify any wiring harness components installed or connected to the scooter under any circumstances.
- Violating the above requirements may lead to unforeseen damages.
- Do not use non-compliant batteries, such as non-rechargeable lead-acid batteries. Please read the relevant information about the battery and charger before installation.

This mobility scooter has successfully passed the ISO 7176-9 climate testing standard, ensuring users or caregivers have sufficient time to move the mobility scooter to a safe location during rain.

- Do not operate the mobility scooter during thunderstorms.
- Do not expose the mobility scooter to any form of heavy rain.
- Do not use the mobility scooter in the shower or place it in damp environments such as bathrooms or saunas.
- Do not store the mobility scooter in excessively humid locations for extended periods.
- Do not clean the mobility scooter by spraying, hosing, or using an automatic car wash.

Direct exposure to rain, saltwater, or humid air may cause electrical component failure and mechanical rust. Exposure to these conditions may lead to electrical or mechanical malfunctions, as well as corrosion.

- Maximum user weight limit: 120 kg
- Overall noise level: ≤ 70 decibels



The symbol above indicates that, in accordance with local laws and regulations, your product should be disposed of separately from household waste. When this product reaches the end of its life, please take it to a designated recycling center specified by local authorities. Proper sorting and recycling during disposal will help conserve natural resources and ensure the product is recycled in an environmentally friendly manner.

Ensure that you are the lawful owner of the product being disposed of before proceeding according to the above recommendations.

Warning labels are affixed to the body of the mobility scooter:

Pinch Point Warning Label

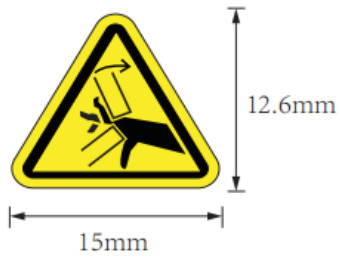

Load Capacity Warning Label

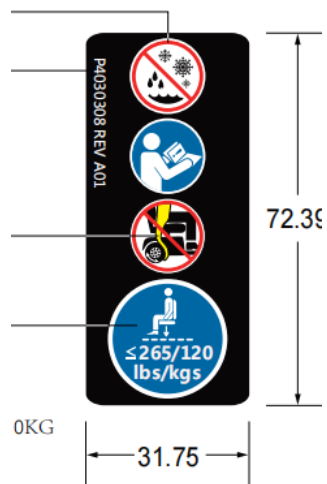

15.EMC(EMI) WARNINGS



IT IS VERY IMPORTANT THAT YOU READ THIS INFORMATION REGARDING THE POSSIBLE EFFECTS OF ELECTRO MAGNETIC CONTAMINATION (EMC) ON YOUR MOBILITY SCOOTER. SOMETIMES THIS EFFECT IS ALSO KNOWN AS ELECTRO MAGNETIC INTERFERENCE (EMI). EMC (EMI) FROM RADIO-WAVE SOURCES.

Mobility scooters may be susceptible to EMC, which is interference from electromagnetic energy (EM) emitted from sources such as radio stations, TV stations, amateur (HAM) radio transmitters, two way radios and mobile phones. The interference (from radio sources) can cause the mobility scooter to release its brakes, move by itself, or move in an unintended way. Permanent damage can also be done to the mobility scooter's control system.

The intensity of the interfering EM energy can be measured in volts per meter (V/m.).

Each mobility scooter can resist EMC up to a certain intensity. This is known as the mobility scooter's "immunity level". The higher the immunity level, the greater the protection.

Current technology offers useful protection of at least 20 V/m. which provides protection from the more common sources of radiated EMC. There are a number of relatively strong electromagnetic fields present in the everyday environment. Most of these sources are obvious and easy to avoid, others are not so obvious and can be unavoidable.

By following the warnings listed, your risk of exposure to EMC will be minimized.

EMC sources can be broadly classified into three types:

1. Hand-held portable transceivers (transmitter-receivers with on-board antenna). Examples are Walkie-Talkie, CB Radio, security, emergency services and mobile phones. Note that some cellular phones can transmit signals while they are switched on but not being used.
2. Medium range mobile transmitters such as those used on emergency services vehicles, taxis etc. These usually have antennae mounted on the outside of the vehicle.
3. Long-range transmitters and transceivers, such as commercial broadcast transmitters (radio and TV broadcast antenna towers) and amateur (HAM) radios.

Note: Other types of hand-held devices such as cordless phones, laptop computers, AM/FM radios, TV sets, CD players, cassette players and small appliances, such as electric shavers and hair dryers, are not likely to cause any EMC problems to your mobility scooter.

Mobility scooter electromagnetic contamination (EMC).

EM energy rapidly intensifies the closer one moves to the transmitting antenna, the source. Because of this it is possible to bring strong EM fields unintentionally close to your mobility scooter's control system. Mobile hand-held radio type transceivers are of particular concern. Whilst such devices are in use, it is possible that the EM radiation can affect the mobility scooter's movement and braking.

The following warnings are recommended to help prevent possible interference with your mobility scooter's control system.

1. Do not operate hand-held transceivers, such as CB radio or turn ON cellular phones, whilst your mobility scooter is turned ON.
2. Be aware of nearby radio or television transmitters and try to avoid coming too close to them.
3. If you experience unintended movement or brake release, switch your scooter OFF as soon as it is safe to do so.
4. Adding accessories, components or modifying the mobility scooter, may increase susceptibility to EMC (EMI).



Note: There is no easy way of assessing the effect of any modification on a mobility scooter's EM immunity.

5. If you experience any EMC (EMI) related incidents, please report them to your dealer, noting if there is a possible source of EM transmission nearby.



Note:

1. This mobility scooter complies with the IEC 60601-1-2 standard for electromagnetic requirements.
2. Please assemble or operate the mobility scooter according to the user manual.
3. Portable or mobile RF communication devices may interfere with the mobility scooter. Keep it away from devices such as mobile phones or microwave ovens to avoid electromagnetic interference.
4. For guidelines and manufacturer declarations, refer to the attached documents.



Note:

1. This device or system should be kept away from other equipment. If they must be put together, pls check whether the device or system can run normally.

2. You should consider the original manufacturer of the device or system as the sole supplier. Failure to do so may cause EMC increase and or decrease anti-EMC ability.

Attachments :

Guidance and manufacturer's Declaration–electromagnetic emission		
SW1000A3 is intended for use in the electromagnetic environment specified below. The customer or the user of the SW1000A3 should assure that it is used in such an environment.		
Emission Test	Compliance	Electromagnetic environment–guidance
RF Emission CISPR 11	Group 1	SW1000A3 use RF energy only for its internal function. Therefore, it's RF emissions are very low and are not likely to cause any interference in nearby electronic equipment.
RF Emission CISPR 11	Class B	SW1000A3 is suitable for use in all establishments, including domestic establishment and those directly connected to the public low-voltage power supply network that supplies buildings used for domestic purposes.
Harmonic Emissions IEC 61000S-3-2	Class A	
Voltage fluctuation/flicker emissions IEC 61000S-3-3	complies	

Guidance and manufacturer's Declaration–electromagnetic emission
SW1000A3 is intended for use in the electromagnetic environment specified below. The customer or the user of the SW1000A3 should assure that it is used in such an environment.

Immunity test	IEC 60601 test level	Compliance level	electromagnetic environment-guidance
Electrostatic discharge (ESD) IEC 61000S-4-2	±6 kV contact ±8 kV air	±6 kV contact ±8 kV air	Floors should be wood, concrete or ceramic tile. If floors are covered with synthetic material, the relative humidity should be at least 30%.
Electrical fast transient/ burst IEC 61000S-4-4	±2kV for power supply lines ±1kV for input/ output lines	±2kV for power supply lines ±1kV for input/ output lines	Mains power quality should be that of a typical commercial or hospital environment.
Surge IEC 61000S-4-5	±1 kV differential mode ±2 kV common mode	±1 kV differential mode ±2 kV common mode	Mains power quality should be that of a typical commercial or hospital environment.
Voltage dips, short interruptions and voltage variations on power supply input lines. IEC 61000S-4-11	<5 % UT, (>95% dip in, UT) for 0.5 cycle 40 % UT (60% dip in, UT) for 5 cycles 70 % UT, (30% dip in, UT) for 25 cycles <5 % UT, (>95% dip in, UT) for 5 sec		Mains power quality should be that of a typical commercial or hospital environment. If the use of the SW1000A3 requires continued operation during power mains interruptions, it is recommended that the SW1000A3 be powered from an uninterruptible power supply or a battery. Power frequency magnetic fields should be at levels characteristic of a typical location in a typical commercial or hospital environment.
Power frequency (50/60Hz) magnetic field IEC 61000S-4-8	3A/m		
NOTE: UT is the ac mains voltage prior to application of the test level.			
Guidance and manufacturer's Declaration—electromagnetic immunity			
SW1000A3 is intended for use in the electromagnetic environment specified below. The customer or the user of the SW1000A3 should assure that it is used in such an environment.			
Immunity test	IEC 60601 test level	Compliance level	electromagnetic environment-guidance
Conducted RF IEC 61000S-4-6	3 Vrms 150 kHz to 80 MHz	3 Vrms	Portable and mobile RF communications equipment

<p>Radiated RF IEC 61000S-4-3</p>	<p>3 V/m 80 MHz to 2.5 GHz</p>	<p>3 V/m</p>	<p>should be used or closer to any part of the SW1000A3, including cables, than the recommended separation distance calculated from the equation applicable to the frequency of the transmitter.</p> <p>Recommended separation distance $d = 1.2 \sqrt{P}$</p> <p>$d = 1.2 \sqrt{P}$ 80 MHz to 800 MHz</p> <p>$d = 2.3 \sqrt{P}$ 800 MHz to 2.5 GHz</p> <p>Where P is the maximum output power rating of the transmitter in watts(W) according to the transmitter manufacturer and d is the recommended separation distance in the meters(m).</p> <p>b Field strengths from fixed RF transmitters, as determined by an electromagnetic site survey, should be less than the compliance level in each frequency range.</p> <p>Interference may occur in the vicinity of the equipment marked with the following symbol:</p> 
-----------------------------------	------------------------------------	--------------	--

NOTE 1: At 80MHz and 800MHz, the higher frequency range applies.

NOTE 2: This guidance may not apply in all situations. Electromagnetic propagation is affected by absorption and reflection from structures, objects and people.

Field strengths from fixed transmitters, such as base stations for radio (cellular/cordless) telephones and land mobile radios, amateur radio, AM and FM radio broadcast and TV broadcast cannot be predicted theoretically with accuracy. To assess the electromagnetic environment due to fixed RF transmitters, an electromagnetic site survey should be considered. If the measured field strength in the location in which the [SW1000A3] is used exceeds the applicable RF compliance level above, the [SW1000A3] should be observed to verify normal operation. If abnormal performance is observed, additional measures may be necessary, such as reorienting or relocating the [SW1000A3].
Over the frequency range 150 kHz to 80 MHz, field strengths should be less than 3 V/m.

Recommended separation distances between portable and mobile RF communications equipment and the [SW1000A3]

The [SW1000A3] is intended for use in an electromagnetic environment in which radiated RF disturbances are controlled. The customer or the user of the [SW1000A3] can help prevent electromagnetic interference by maintaining a minimum distance between portable and mobile RF communications equipment (transmitters) and the [SW1000A3] as recommended below, according to the maximum output power of the communications equipment.

Rated maximum output power of transmitter /W	Separation distance according to frequency of transmitter /m		
	150 kHz ~ 80 MHz d = 1.2 P	80 MHz ~ 800 MHz d = 1.2 P	800 MHz ~ 2.5 GHz d = 2.3 P
0.01	0.12	0.12	0.23
0.1	0.38	0.38	0.73
1	1.2	1.2	2.3
10	3.8	3.8	7.3
100	12	12	23

For transmitters rated at a maximum output power not listed above, the recommended separation distance d in meters (m) can be estimated using the equation applicable to the frequency of the transmitter, where P is the maximum output power rating of the transmitter in watts (W) according to the transmitter manufacturer.

NOTE 1 At 80 MHz and 800 MHz, the separation distance for the higher frequency range applies.

NOTE 2 These guidelines may not apply in all situations. Electromagnetic propagation is affected by absorption and reflection from structures, objects and people.

16.SPECIFICATIONS

Measured values are for reference only; slight variations may occur.

PARAMETER	SW1000A3
LENGTH	1067mm
REAR WIDTH	602-646mm
HEIGHT	872-910mm
MAX. USER WEIGHT	120 kg (264 lbs)
BATTERY CAPACITY	12 AH Lead-acid
MAX SAFE SLOPE	6° at 120kg (120 kg)
SEAT HEIGHT	419~457mm
MAX SPEED	6,5 km/h (4,1 mph)
MINI TURNING RADIUS	1385mm
FRONT WHEEL SIZE	203*48mm
REAR WHEEL SIZE	203*62mm
CHARGER	DC24V2A AC100-240V
CHARGING TIME	6-8h
TOTAL WEIGHT WITH BATTERY	47 KG
TOTAL WEIGHT WITHOUT BATTERY	36.5KG
SEAT WEIGHT	10.50KG
BATTERY WEIGHT	9.40KG
GROUND CLEARANCE	32mm
CONTROLLER	Dynamic DR50
MOTOR	300W
BRAKE SYSTEM	Electromagnetic Brake
VOLTAGE	24VDC
VOLTAGE TYPE	D.C.24V
OBSTACLE CLEARANCE HEIGHT	57.5mm
DRIVING RANGE	Up to 8.9 miles (14.4 km) at 265 lbs. (120 kg); 18 stone 13 lbs. Up to 11.5 miles (18.5 km) at 200 lbs (90.75 kg); 14 stone 4 lbs.

The mobility scooter complies with the following standards:

- a) Static, impact and strength requirements and test methods (ISO 7176-8)
- b) Power and control systems for electric mobility scooters - Requirements and test methods (ISO 7176-14)
- c) Testing of mobility scooters for weathering according to ISO7176-9
- d) Anti-ignition requirements according to ISO7176-16

17.ROUTINE MAINTENANCE

The following table gives an indication as to when routine maintenance checks should be made.

There is no service manual available. Maintenance, fault finding and servicing should be carried out by an authorized dealer unless otherwise indicated	Daily	Weekly	Quarterly	Annually
The checks below can be carried out by the user				
Battery charge check (Figure 17.3) Look at battery charge indicator on tiller before use to ensure batteries carefully charged.	•			
Wipe over with a damp cloth Use a damp soft cloth and mild detergent on panels, battery wells, tiller and seat.		•		
Check tyres Each tyre should be free of debris, oil, deep cuts or distortion.		•		
Long overnight battery charge Please ensure that the batteries are charged for a minimum of 8 hours.		•		
Check tyres for wear (See Figure 17.1 and Figure 17.2) Look at the tyres to ensure that the tread is visible and continuous.			•	
The checks below must be carried out by an authorized dealer				
Seat swivel, seat slide (where fitted)				•
Inspection of wiring and connectors for chafing and wear				•
Battery terminals				•
Clean and protect with petroleum jelly.				
Ensure parking brake (where fitted) is correctly adjusted				•
Check stabilizer wheels for wear				•
Inspect motor brushes				•
Full service by dealer				•



Figure 17.1

Figure 17.2

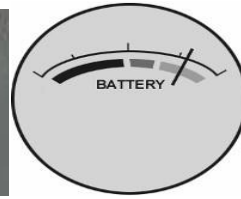

Figure 17.3

Storage

When you need to store your mobility scooter for an extended period (more than a week), charge it fully for 12 hours and disconnect the battery to minimize discharge.

Electronic Faults

Do not attempt to troubleshoot controller failures. The design and layout of the controller or charger's electronic components are safety-certified. Spare parts and follow-up services can be obtained from authorized dealers.



Note: Before replacing the LED light, please disconnect the battery and have it replaced by an authorized dealer.

Tires



Note: The wheels can only be removed and reassembled by authorized dealers. Preparation Instructions After Long-Term Storage of the Vehicle.

Vehicle Cleaning

1. Body Cleaning: wipe the body with a clean, damp cloth, especially areas like the wheels, frame, and handlebars where dirt tends to accumulate.
2. Battery Compartment Cleaning: clean the surface of the battery compartment to prevent dust and moisture from entering, which may affect the battery's normal operation.
3. Brake System Cleaning: check the brake system to ensure the brakes are responsive.

Tire Maintenance

1. Sufficient Air Pressure: Before parking, inflate the tires to the standard pressure to avoid deformation, which could affect the tire's lifespan and driving performance.
2. Check for Wear and Aging: Inspect the tires for wear and aging. Replace the tires if necessary.

Brake System Check

Check the sensitivity of the brake system to ensure proper operation. If any issues are found, it is recommended to have the system repaired by a professional.

Light and Horn Check

1. Light Check: Turn on the lights and check if the lighting works properly.
2. Horn Check: Press the horn and listen for a loud sound to ensure it functions properly.

18.SERVICE HISTORY

This section is designed to assist you in keeping a record of any service and repairs to your mobility scooter. Should you decide to sell or exchange your vehicle in the future, this will prove most helpful to you. Your Service Agent will also benefit from a documented record and this manual should accompany the mobility scooter when service or repair work is carried out. The Service Agent will complete this section and return the manual to you.

Customer Name _____									
Date scooter purchased _____									
Address _____									
Model _____									
Color _____									
Postcode _____									
Serial No. _____									
YEAR	1	2	3	4	YEAR	1	2	3	4
Service dates					Service dates				
Controller					Upholstery				
On/off switch					Seat				
Output plug					Back				
Operation					Armrest				
Dynamic braking					Wheels/tyres				
Programmable settings					Wear				
Batteries					Bearings				
Levels					Wheel nuts				
Connections					Test run				
Discharge test					Forwards				
Motors					Reverse				
Wiring					Emergency				

19.TROUBLE SHOOTING GUIDE

SYMPTON	POSSIBLE CAUSE	SOLUTION
Shortened range	Batteries not charged for long enough	Charge batteries for eight hours or more
	Batteries weak and cannot hold charge	Replace battery pack
Battery pack not charging or battery gauge shows empty after charging	Battery pack fault	Replace charger
	Charge fault	Contact local mobility dealer
	Charger loom or plug damaged	Check plugs and looms
	Loose connection	Try a wall socket in a different room
	No output from wall outlet	Unplug from wall & change fuse
	Fuse in charger mains plug blown	Switch off and press button back in
	Button on battery pack has popped out	Switch off and press button back in
	Output fuse in charger blown	Unplug from wall and contact dealer
Battery charging current high	Faulty batteries	Replace battery pack
	Scooter switched on during charging	Turn Scooter off
Unable to drive	Brake-release lever disengaged	Engage brake-release lever
	Flat batteries	Charge battery pack
	Scooter is not switched on with key	Ensure the key is switched on

Unable to drive	Battery pack not engaged properly	Check battery pack is fully engaged onto connectors
	Charger plugged in	Unplug charger
	Button on battery pack popped out	Reset circuit-breaker button
	Disconnected loom or plugs	Check all plugs & looms
	Control system fault	Contact dealer
Motor runs irregularly and/or noisily	Electrical malfunction	Contact dealer
	Control system fault	Contact dealer
DO NOT ATTEMPT TO OPEN ANY PARTS OF THE SCOOTER CONTROL SYSTEM, BATTERY PACK, LOOMS, PLUGS OR BATTERY CHARGER. THE CONTROL SYSTEM IS SAFETY CRITICAL AND THERE ARE NO USER SERVICEABLE PARTS		

Your mobility scooter is fitted with a self diagnostic controller that will give a sequence of audible beeps when an error is detected to help you, or the authorized service agent, determine the drive electronics fault.

Should you switch on the mobility scooter and hear the beeps note the number of beeps, separated by a short delay between each sequence, and refer to the table below.

NUMBER OF BEEPS	REPRESENT	POSSIBLE CAUSE	SOLUTION
1	Battery power low	Power not enough	The battery needs charging
2	Low battery voltage	Power not enough	The battery needs charging
3	High battery voltage	Too higher voltage, while overloading or climbing	Decrease speed while climbing
			Check battery connection
4	electric current over limit	electric current over limit of motor	Check motor and relative wiring connections
			Switch off and wait a few minutes and Switch on.

5	Freewheel level issue	The freewheel level is on	Check the relative wiring of the freewheel level
			Confirm the level is on the correct position
6	Accelerate the variable resistor issue	When turning on the controller, accelerate variable resistor isn't on the neutral position	Make sure the accelerate variable resistor is on the neutral position
			Accelerate variable resistor may need to recalibration.
7	Speed limited variable resistor issue	accelerate variable resistor, Speed limited variable resistor or other wiring issue	Check all the accelerate variable resistor, Speed limited variable resistor or other wiring
8	Motor voltage issue	Motor and other relative wirings issue	Check Motor and other relative wirings
9	Other issues	Some inner issues in the controller	Check all the connection and wirings
10	Pushing / Slipping issues	The speed of pushing or slipping is over limited	Switch off and on the controller

20.WARRANTY

Two-year limited warranty

Structural frame component and shroud.

One-year limited warranty

Drivetrain parts (transaxle, motor and brake), all electrical parts, including controllers ,battery and battery chargers are covered for one year under warranty.

Any attempt to open or dismantle these parts will lead to this warranty being void.

Not Covered Under Warranty

The following are classed as wear items, which may, under normal wear and tear, require replacing. The items are not therefore covered under warranty include tyres, lap belts, bulbs, upholstery, plastic shrouds, motor brushes and fuses. Warranty will also be refused if damage is deemed to have been caused through misuse or accident for which Pride Mobility Products Ltd. cannot be deemed responsible.

NOTE: Pride Mobility Products Ltd. provides parts only under warranty. Your authorised Pride Dealer is responsible for labour and service. Please contact your authorised Pride Dealer for information about these services and for any applicable charges.



Manufacturer:

Suzhou Sweetrich Vehicle Industry Technology Co., LTD.

Building B, No.7 Chao Qian Road, Suzhou Industrial Park ,Suzhou, Jiangsu Province, China

Tel : +86-512-82283873

E-mail : Info@sweetrich.cn



Importers:

Pride Mobility Products Ltd

32 Wedgwood Rd, Bicester OX26 4UL, United Kingdom

Pride Mobility Products GmbH

6-8 Josef-Förster-Straße, 33161 Hövelhof, Germany

Distributor:

Pride Mobility Products Europe BV

De Zwaan 3

1601 MS Enkhuizen, The Netherlands